

PRODUCT DATA SHEET

BIA-NXT • 808034



PRODUCT DETAILS

The nXt series of pump controls represents the next step in pressurised pump control.

Designed and tested in Australia to ensure operation in the toughest of environments, combining innovative technology with robust proven architecture to guarantee constant supply of pressurised water when and where you need it the most.

APPLICATIONS

- Household water supply
- Irrigation
- Water transfer
- Washing systems
- Pressure boosting

FEATURES

- Digital display gives you a real time indication of system pressure
- Anti-cycle Protection
- Dry run protection with auto restart function that tests for water availability every 24hrs
- Anti-seize function if pump has not operated for last 24 hours
- Controller automatically restarts pump after a power failure
- Easy assembly and removal using push-n-connect fitting with U clip
- Complies to AS/NZ 4020 drinking water standard
- Over pressure protection turns pump off when 10 bar is reached
- Overload protection

TECHNICAL DATA

FUNCTION	ON / OFF
MODES	1
SIZE (KW)	1.5
RATED VOLTAGE (V)	220-240 AC
MAX AMPS	10
RATED POWER	1500w
RATING	IP65
UNION SIZE	1"
START PRESSURE	2.2 bar (32PSi)

STOP PRESSURE	on no flow
MAX PRESSURE	10 bar (145PSI)
MAX LIQUID TEMP	40°C
CABLE TO PUMP	Plug and Play
FLYLEAD FOR PUMP	When sold as control only
POWER CABLE	10AMP
COMMUNICATION	-
ACCESSORIES (SOLD SEPARATELY)	-
	1 ¼" Union Kit

CURVE

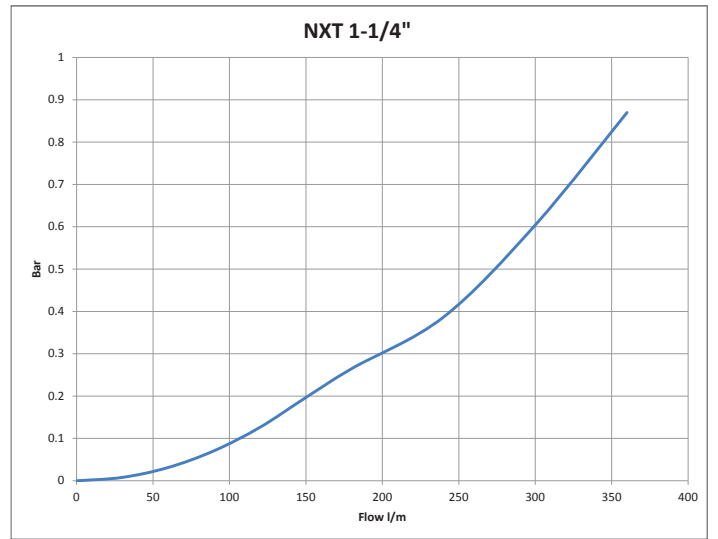
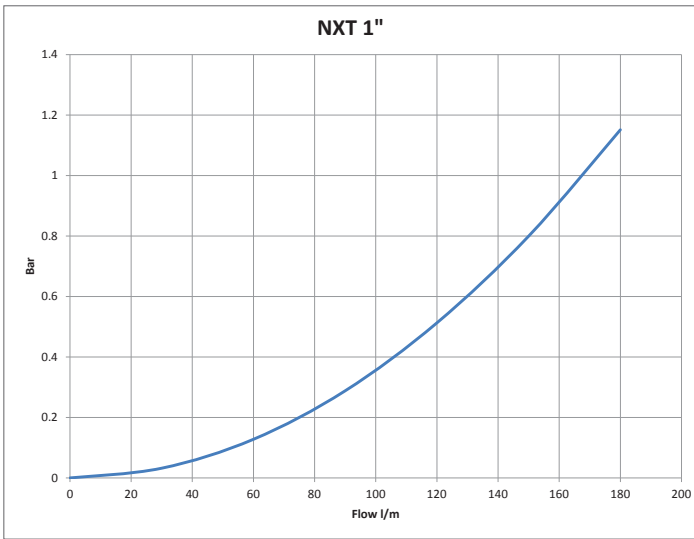

DIMENSIONS

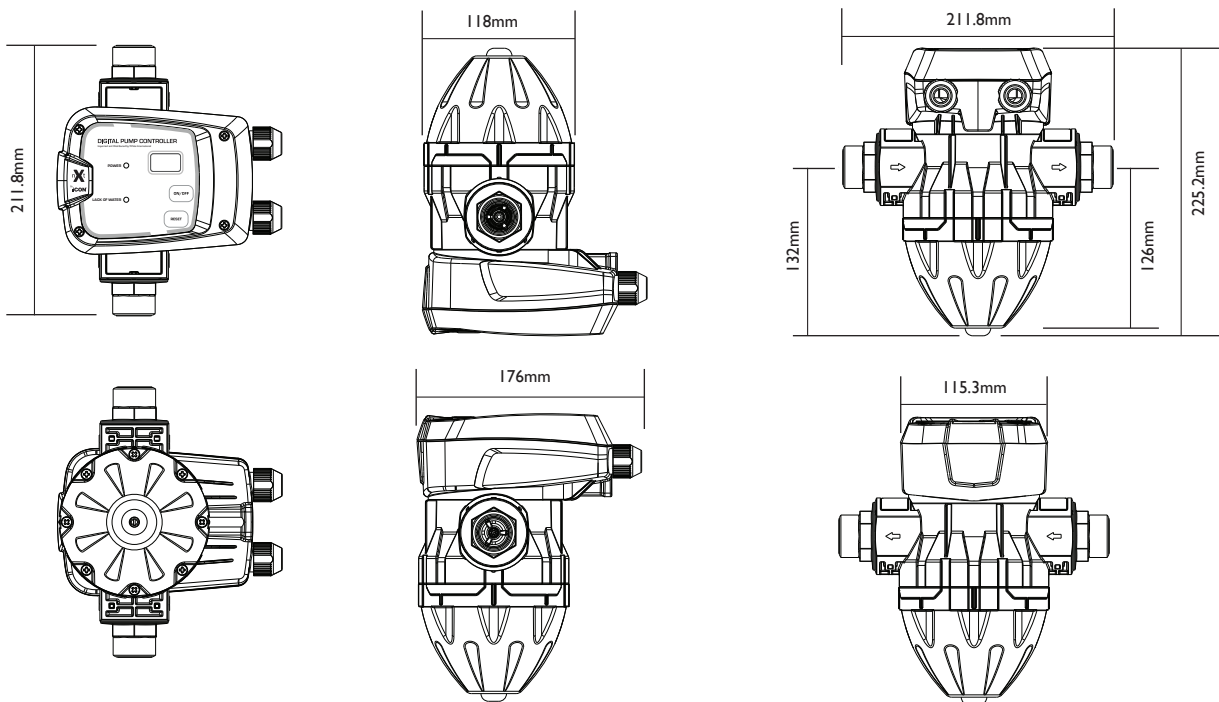

WARRANTY / CERTIFICATIONS

